

EC650B

Eaton's Cooper BACnet Gateway



The BACnet gateway (EC650B) is a CEA-709/ BACnet gateway which maps CEA-709 network variables (NVs) to standard BACnet server objects. When ordered with this part code EC650B, the LonWorks to BACnet address mapping is pre-loaded and ready for use with the Cooper intelligent addressable CF3000 system interface board.

NVs are mapped to binary or intelligent addressable objects (inputs and outputs) according to CEN/TS 15231:2005. Scalar NVs are mapped to one BACnet object. Structured NVs are mapped to several BACnet objects, one for each member (members can be selected individually).

BMS systems can subscribe and synchronise to a set of BACnet server objects that are updated each time a status change occurs anywhere in the fire system.

Features

- Fully compliant with ANSI/ASHRAE 135-2004 and ISO 16484-5
- Maps network variables to BACnet server objects based on CEN/TS 15231:2005
- Supports one BACnet MS/TP or BACnet/IP channel (configurable)
- Event-driven email notification
- BACnet/IP and BACnet/MSTP activity LED

Benefits

- Easy to configure
- DIL rail mount
- Permits several Cooper panels to connect to 3rd party BACnet BMS system

BACnet Addresses

Object Name	Type	Description
System Events		
RxPanelData_CmdStatus	Binary Input	
RxPanelData_PanelNumber	Analogue Input	System event data consists of 31 BACnet server objects that update simultaneously when a fire system event is generated by any control panel in the system. BMS systems should take care to subscribe to each update event synchronously and not poll these objects.
RxPanelData_CmdStatusNumber	Analogue Input	
RxPanelData_Address	Analogue Input	
RxPanelData_Analogue	Analogue Input	
RxPanelData_Zone	Analogue Input	
RxPanelData_Loop	Analogue Input	
RxPanelData_Always_1	Binary Input	
RxPanelData_TypeID	Analogue Input	
RxPanelData_Location_1...25	Analogue Input	
System Command Status		
nviReset_state	Binary Input	System Reset Status
nviEvacuate_state	Binary Input	System Evacuation Status
nviSilence_state	Binary Input	System Silence Status
System Command Action		
nvoReset_state	Binary Output	Send Reset Command
nvoEvacuate_state	Binary Output	Send Evacuate Command
nvoSilence_state	Binary Output	Send Silence Command
Additional Info		
Id_in	Analogue Input	Panel Id of Last Event
nviLoop	Analogue Input	Loop Id of Last Event

Typical System Architecture

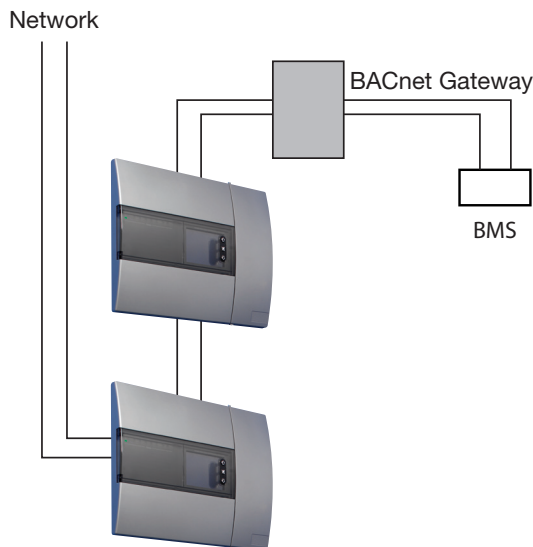

Dimensions

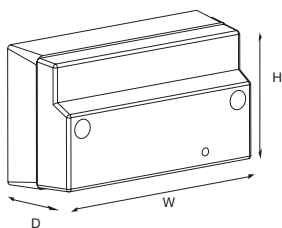

H (mm)	W (mm)	D (mm)
60	105	86

Communication and Automation Functions

On the CEA-709 side, the EC650B supports either the ethernet/IP (IP-852) channel or the TP/FT-10 channel (configurable).

The BACnet server objects are accessible from the BACnet network where BACnet/IP or BACnet MS/TP is supported (configurable).

Additionally:

L-GATE supports basic automation functions such as alarming, scheduling, and trending for a seamless integration of CEA-709 applications in a BACnet network.

L-GATE features event driven email notifications for pre-defined actions. This way, the user is promptly informed about problems such as a specific status or an exceeded high-limit.

Network Variables

Easy and fast mapping of network variables to BACnet server objects is guaranteed with the gateway configuration utility supplied with the unit. The software can run as a stand alone tool, connecting to the EC650B via FTP or as an LNS® plug-in, compatible with LNS® 3.0 and LNS® TE applications like NL220, ALEX and LonMaker®.

Catalogue numbers

Description	Code
BACnet Gateway	EC650B